

## Model 197 Battery Operated Stretcher Lift

Model 197 Battery Operated Stretcher lift is designed to help reduce strain on the attendant's back while transferring patients to a variety of full-body whirlpools, tanks and tubs. This lift has a hand-operated remote height control, two 12-volt batteries, built-in charger, and push handles. The stretcher can be adjusted to three positions on both ends and is fire retardant and waterproof. The lift can be operated up to 40 hours per charge. There is an optional chair attachment.

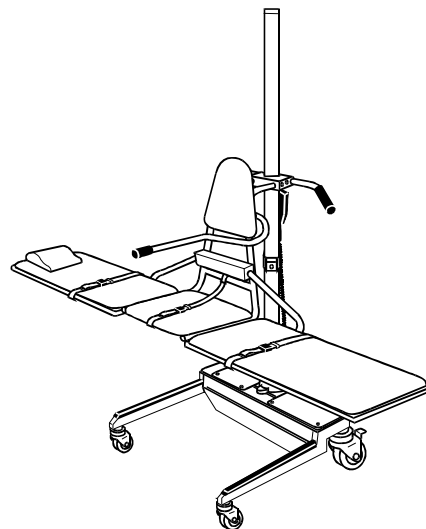

### Lift

The frame is constructed of epoxy-painted tubular steel and the mast is triple-plated chrome tubing. The stretcher is tubular steel with an epoxy-coated finish with removable, molded, fire retardant, polyurethane cushions for easy cleaning and disinfecting and a vinyl coated pillow. The stretcher is adjustable on both ends to three positions. The stretcher has three safety belts.

The lift features 5" locking rear casters with straight steering device and dual 3" front wheels.

The hand-held remote control has a flexible cable.

The lift mechanism is a ball screw actuator with a 12 V DC motor equipped with a built-in battery charger and two 12 volt rechargeable batteries. The LED low battery display is located on the base. The lift can not be operated when the batteries are charging.

### Optional Accessories

- Chair
- Wall Brackets (for storage of accessories)

## Specifications

### Mechanical

A. Length .....	34 in .....	86 cm
B. Width .....	34 in .....	86 cm
C. Height		
max .....	88 in .....	224 cm
min .....	56 in .....	142 cm
D. Total Depth .....	42 in .....	107 cm
E. Leg Clearance .....	7 in .....	18 cm
F. Space Between Chair Back and Mast		
Middle .....	4 in .....	10 cm
Lower .....	10 in .....	25 cm
Travel .....	32 in .....	81 cm
Weight .....	180 lb .....	82 kg
Load Limit .....	330 lb .....	150 kg

### Stretcher

G. Length .....	79 in .....	201 cm
H. Width .....	18 in .....	46 cm

### Electrical

Motor, 12V DC 22 amp full load, permanent magnet field, reversible.

Rechargeable Battery, 12 Volt D.C.  
Charger 115 Volt A.C. 60 Hz 3 Amps.

Most specifications are rounded to whole numbers.  
Contact Ferno Customer Service for detailed specifications.  
Ferno reserves the right to change specifications without notice.

## Front View

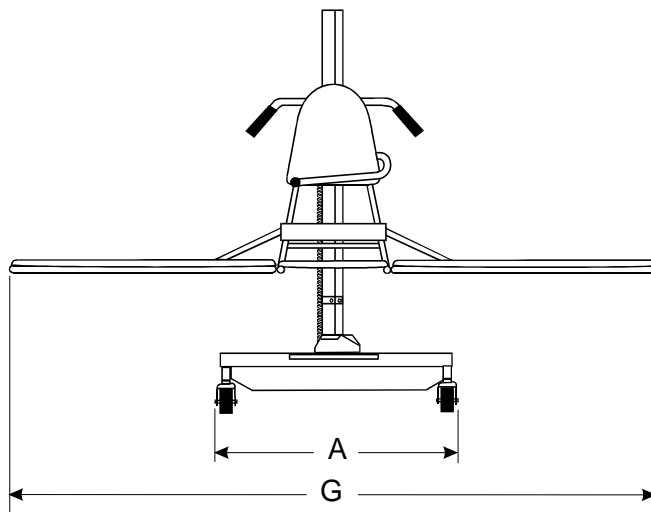

## Side View

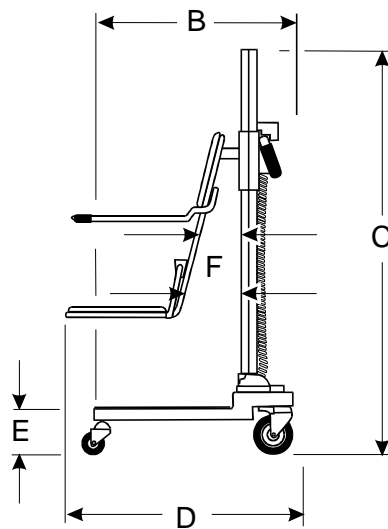

## Contact Customer Service at:

Ferno-Washington, Inc.  
70 Weil Way  
Wilmington, OH 45177-9371  
Phone ..... 800.733.3766  
                          937.382.1451  
Fax ..... 937.382.1191